

**Wheelchair I.D. System
AL-72350**

1. Remove two middle screws from right side of chair back.
2. Slide bracket between upholstery and chair frame and align top screw hole.
3. Reinstall both screws.
4. Fill in patient data on label using indelible pen and adhere to outer surface of bracket.

NOTE

Replace label when applicable patient data changes.

If pressure washing wheelchair, avoid direct pressure on label to prevent accidental removal.

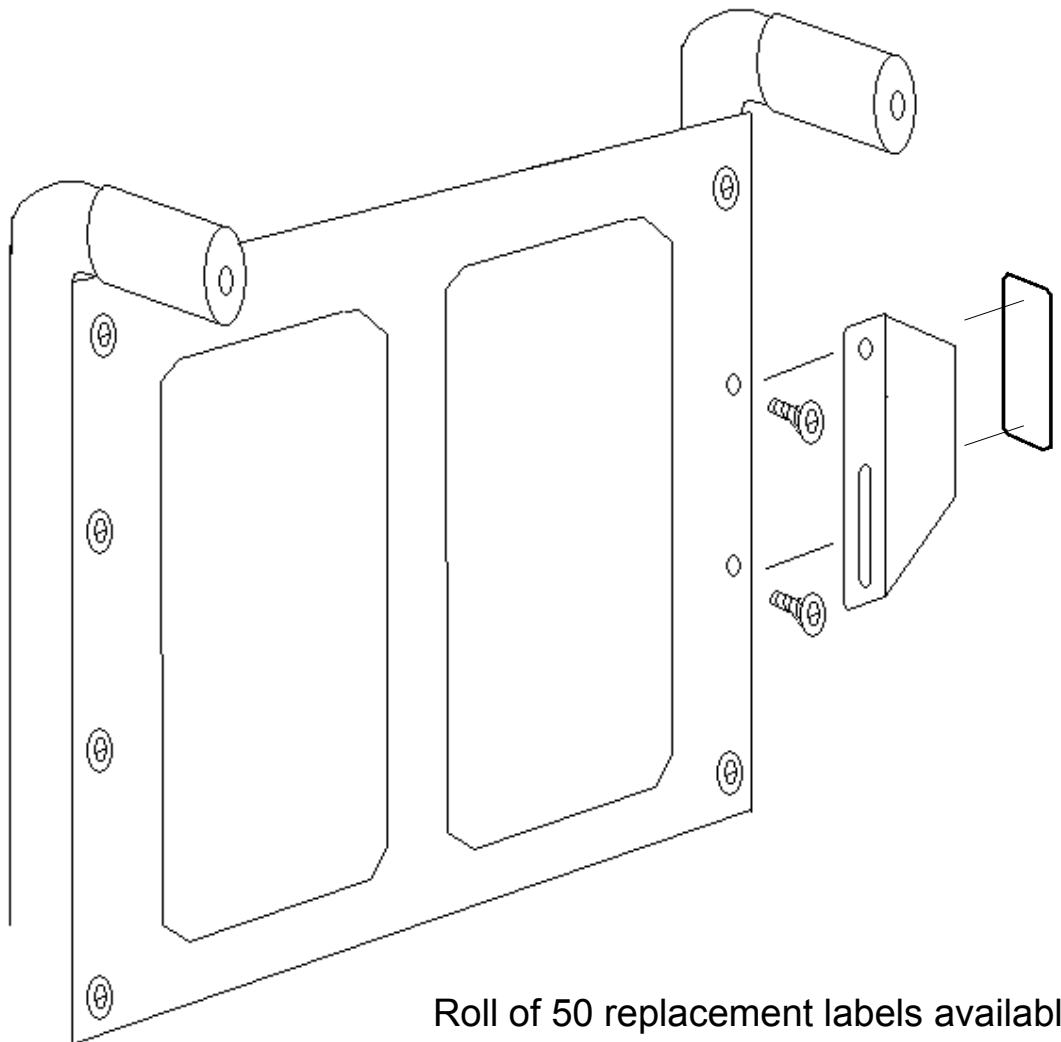

Roll of 50 replacement labels available

Call