

### FEATURES:

- STA-TITE<sup>®</sup>  
Commercial Fastening System™  
Eliminates callbacks for loosened seats

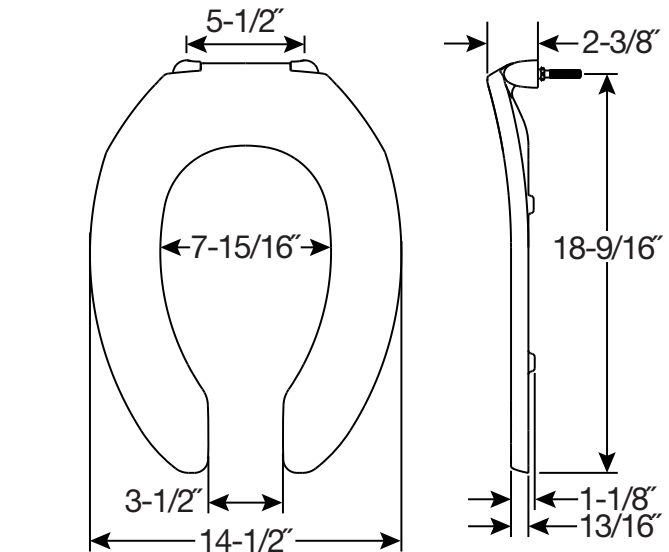

### SPECIFICATIONS:

**Size:** Elongated

**Material:** Plastic

**Style:** Open Front less Cover

**Ring Bumpers:** Four

**Hinges:** Plastic Non Self-Sustaining Check Hinges

**Hardware:** STA-TITE<sup>®</sup> Commercial Fastening System™

### Codes & Standards:



Complies with  
IAPMO/ANSI Z124.5  
Performance Standards  
Heavy-Duty Commercial



Proudly Made in the USA

Eco-Friendly

